

This Manual Must Be Read Before Operating The Equipment

Owner / Operator's Manual



The Commercial Turf Choice

FOR MODELS

MS-1875

MS-2000



Warren, Michigan 48089
800-725-8377

CUSTOMER COPY

Protected by the following patents, #6,089,478, #6,088,865, #Des.425,915
and other pending U.S. and foreign patent applications.

Introduction	3
General Information and Registration	4
Safety Information	5-8
Spreader Assembly and Exploded Views	9-22
Wiring Instructions	23
Electrical System Information	24-28
Spreader Mounting System	29-31
Spreader Maintenance	32
Spreader Operating Information	33-34
Blank Pages	35-36
Determine Vehicle Payload Chart	37
Trouble Shooting	38-40
Blank Page	41
Warranty	42-43

This manual has been designed for your help. It will assist you and instruct you on the proper set-up, installation and use of this spreader.

Refer to the table of contents for an outline of this manual.

We require that you read and understand the contents of this manual completely (especially all safety information) before attempting any procedure contained herein.



THIS SIGN SHOULD ALERT YOU:

The Society of Automotive Engineers has adopted this SAFETY ALERT SYMBOL to pinpoint characteristics that, if NOT carefully followed, can create a safety hazard. When you see this symbol in this manual or on the machine itself, BE ALERT! Your personal safety and the safety of others is involved.

Defined below are the SAFETY ALERT messages and how they will appear in this manual:



DANGER

(RED)

Information that, if not carefully followed, can cause death!



WARNING

(ORANGE)

Information that, if not carefully followed, can cause serious personal injury or death!



CAUTION

(YELLOW)

Information that, if not carefully followed, can cause minor injury or damage to equipment.

General Information



CONGRATULATIONS!

The Turfex product you have purchased is an example of turf management product at its finest! Your Turfex product's, self contained design is a trademark of all Turfex products. Here's why...

SIMPLICITY: Fewer moving parts manufactured of higher quality means minimal maintenance for your Turfex product.

RELIABILITY: High impact linear low density polyethylene hopper, state-of-the-art electronic dual variable speed control, custom engineered powder coated frame, maximum torque 12 volt motor coupled to a custom engineered transmission found only on Turfex products.

VERSATILITY: Multi-use capabilities allows spreading of a variety of materials.

WARRANTY: **ONE YEAR** from date of installation.

The benefits you are about to recognize are that of time, money and effort. We welcome you to the world of Turfex Performance.

Registration

Record the following information in this manual for quick reference.

Spreader Model Number _____

Serial Number _____ Controller Serial Number _____

Date of Purchase _____

Dealer Where Purchased _____

When ordering parts, the above information is necessary. This will help to insure that you receive the correct parts.

At the right is a diagram of the ID tag. This tag is located on the frame (where applicable).



Please fill out the warranty card with all the necessary information to validate it. This will also give us a record so that any safety or service information can be communicated to you.



Before attempting any procedure in this book, these safety instructions must be read and understood by all workers who have any part in the preparation or use of this equipment.

For your safety warning and information decals have been placed on this product to remind the operator of safety precautions. If anything happens to mark or destroy the decals, please request new ones from Turfex.



Unit must be strapped down and locked into position before operating vehicle.



Never exceed the Gross Vehicle Weight Rating of vehicle. Failure to do so may limit a vehicles handling characteristics.



Never attempt to take a unit off a truck with material in it.



Never exceed 45 m.p.h. when loaded spreader is attached to vehicle. Braking distances may be increased and handling characteristics may be impaired at speeds above 45 m.p.h.



Never allow children to operate or climb on equipment.
Always check areas to be spread to be sure no hazardous conditions or substances are in the area.
Always inspect unit for defects: broken, worn or bent parts, weakened areas on spreader or mount.



Always shut off vehicle and power source before attempting to attach or detach or service spreader unit. Be sure vehicle/power source is properly braked or chocked.



Always keep hands, feet, and clothing away from power-driven parts. Remember it is the owner's responsibility to communicate information on safe usage and proper maintenance of all equipment.









Always make sure personnel are clear of areas of danger when using equipment. Maintain 60' distance from all bystanders when operating the spreader.



Inspect the unit periodically for defects. Parts that are broken, missing, or worn out must be replaced immediately. The unit, or any part of it should be altered without prior written permission from the manufacturer.



Never use with foreign debris in the spreader.

-  **WARNING** Always inspect pins and latches whenever attaching or detaching spreader, and before traveling.
-  **CAUTION** Never leave material in hopper for long periods of time. Be aware that fertilizers are hygroscopic and will attract atmospheric moisture and harden up.
-  **WARNING** Remember, most accidents are preventable and caused by human error. Exercising of care and precautions must be observed to prevent the possibility of injury to operator or others!
-  **WARNING** Never operate equipment when under the influence of alcohol, drugs, or medication that might alter your judgment and/or reaction time.
-  **WARNING** Before working with the spreader, secure all loose fitting clothing and unrestrained hair.
-  **WARNING** Always wear safety glasses with side shields when servicing spreader. Failure to do this could result in serious injury to the eyes.

All Turfex products have warning labels instructing you about certain safety issues you should be aware of. Below are examples of what to look for and familiarize yourself with. In the event that a label is lost or removed for refinishing reasons, you may obtain new ones from Turfex.



D 6546



D 6859

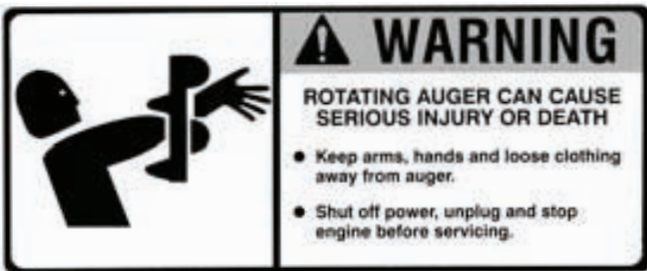

D 6335



D 6545



D 6544



D 6548

It is the responsibility of the person using this equipment to make sure that every type of material is properly calibrated to perform as expected. This process should take place on a solid flat surface away from drains and livestock areas in order to achieve a safe and accurate reading for proper material distribution. Failure to do so may cause an over/under application that could damage turf areas or give an ineffective pest control treatment. Any calibration charts contained in this manual are given as a reference point only and should not be used as an absolute condition. Spending a few extra minutes to properly calibrate will not only save on wasted materials and time but also protect turf and other vegetation. Below are several points to be aware of before operating your spreader in the field.

- Flow rates of chemicals can change for many reasons
 1. Formulations vary within the same brand or even between brands
 2. Formulations vary between batches or dates of manufacture
 3. Humidity can cause the material to clump and flow poorly
 4. Poor spreader maintenance can cause flow changes
 5. Slide stop has moved or calibrated to another type of material
 6. Human error can cause rate miscalculation
- Items needed for calibration
 1. A way to catch the material for weighing
 2. A device to measure distance
 3. A scale to weigh your product
 4. A stop watch or other means to time
- Conversion
 1. To convert pounds per 1000 square feet to pounds per acre, multiply your rate by 43.6
- Other important information
 1. 1 acre is equal to 43,600 Square Feet
 2. Ground speed is very important to keep in mind when doing calculations, you will want to convert mph to feet per minute

Set the spreader stop at mid point on it's travel length as a starting point. Fill the hopper with enough material to cover a known area of 1000 square feet. Open the gate and make note of the start/stop time, this is very important. Next weigh the material on a scale, divide the weight by the known area to establish an application rate. You may have to adjust the gate stop for more or less material depending on your results.

MS-1875

Parts Breakdown

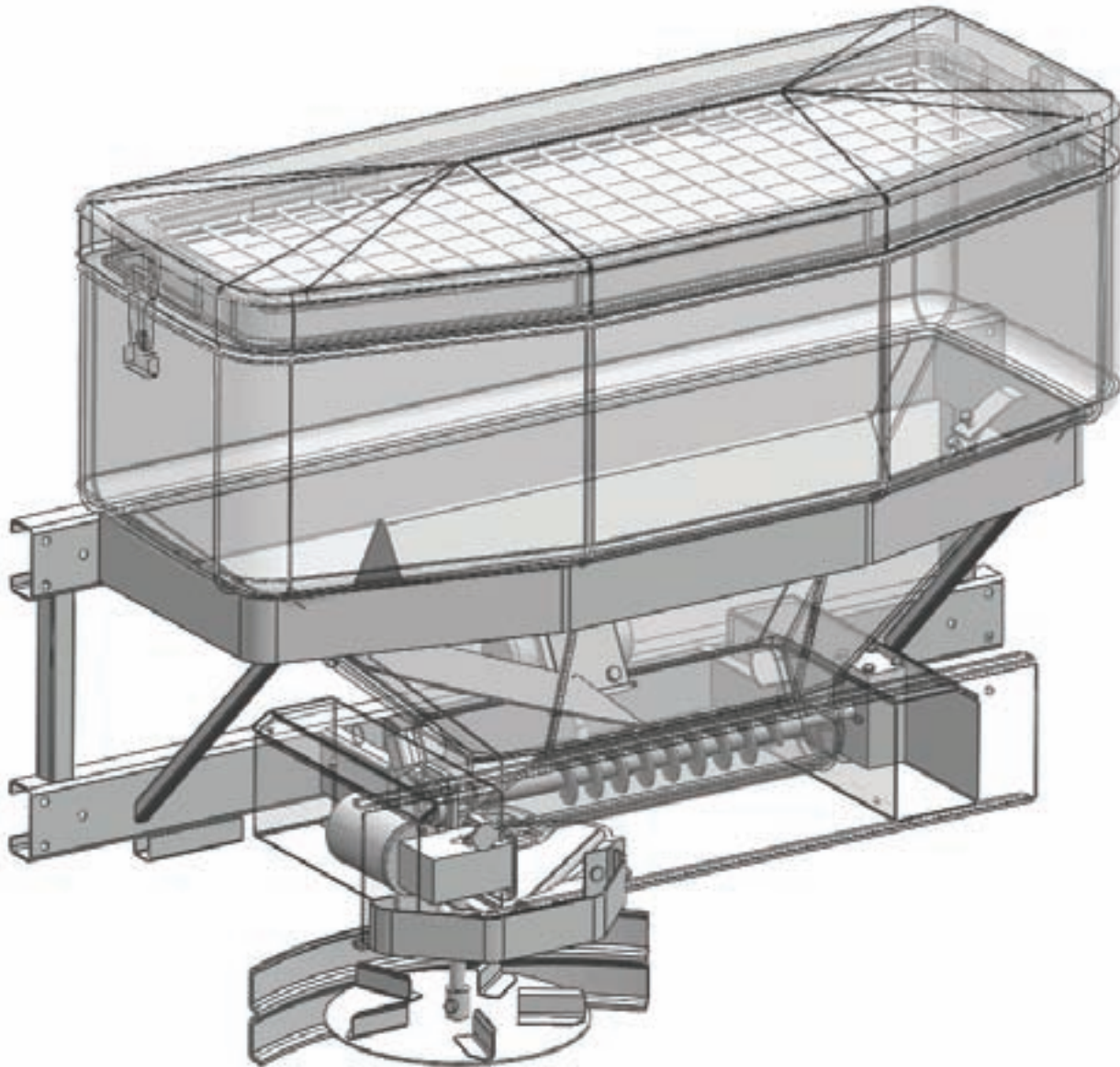

Key	Part No.	Description	Qty.	Key	Part No.	Description	Qty.	Key	Part No.	Description	Qty.
1	D 6452	3/8-16x1" Ser Flg Bolt	2	16	D 6356	Bearing Access Cover	1	31	D 6323	1875 Frame	1
2	D 4122	3/8-16x1-1/2" Hex Bolt	4	17	D 6394	5/16-18 KEPTS Nut	8	32	D 6324	Trim Ring	1
3	D 4124	3/8-16 Lock Nut	8	18	D 6169	3/8" SS Flat Washer	10	33	D 6325	Auger Mtr Motor Cover	1
4	D 6132	1/4-20 x 3/4 Ser Flg SS	8	19	D 6174	DC-80 Vibrator	1	34	D 6326	Spinner Mtr Cover	1
5	D 6105	Flexible Draw Latch	2	20	D 6198	Latch Keeper	2	35	D 6327	Plastic Deflector	1
6	D 6877	#8 x 3/4 Driller	2	21	D 6225	12" Steel Spinner	1	36	D 6328	Inverted V-Support	1
7	D 6130	3/16" Aluminum Rivit	12	22	D 6232	Motor Trans Coupler	2	37	D 6330	Material Baffle	1
8	D 6333	Inverted V-Mtg Brkt	1	23	D 6313	1875 Hopper	1	38	T 30218	1/4-20 X 1-1/4 PH MS SS	4
9	D 6133	5/16-18 x 1/2" Hex Bolt	1	24	D 6314	1875 Lid	1	39	D 4125	3/8 Flat USS Washer	1
10	D 6334	Top Screen	1	25	D 6315	Auger	1	40	T 30217	Tension Spring	4
11	D 6135	10/32 x 5/8" Cap Screw	4	26	D 6317	Spinner Transmission	1	41	T 30211	Adjustable Fin	4
12	D 6333	3/16" Rivet, Long	2	27	D 6501	Auger Transmission	1	42	D 4289	1/4-20 Nylock Nut	4
13	D 6137	5/16-18 x 1" PH SS Bolt	6	28	D 6106	Spinner Motor	1				
14	D 6140	5/16-18 x 3/8" Set Screw	1	29	D 6320	Auger Motor	1				
15	D 6332	Auger Shaft Bearing	1	30	D 6331	Chute	1				

Bulk Material Spreader MS-2000
Side and Bottom View

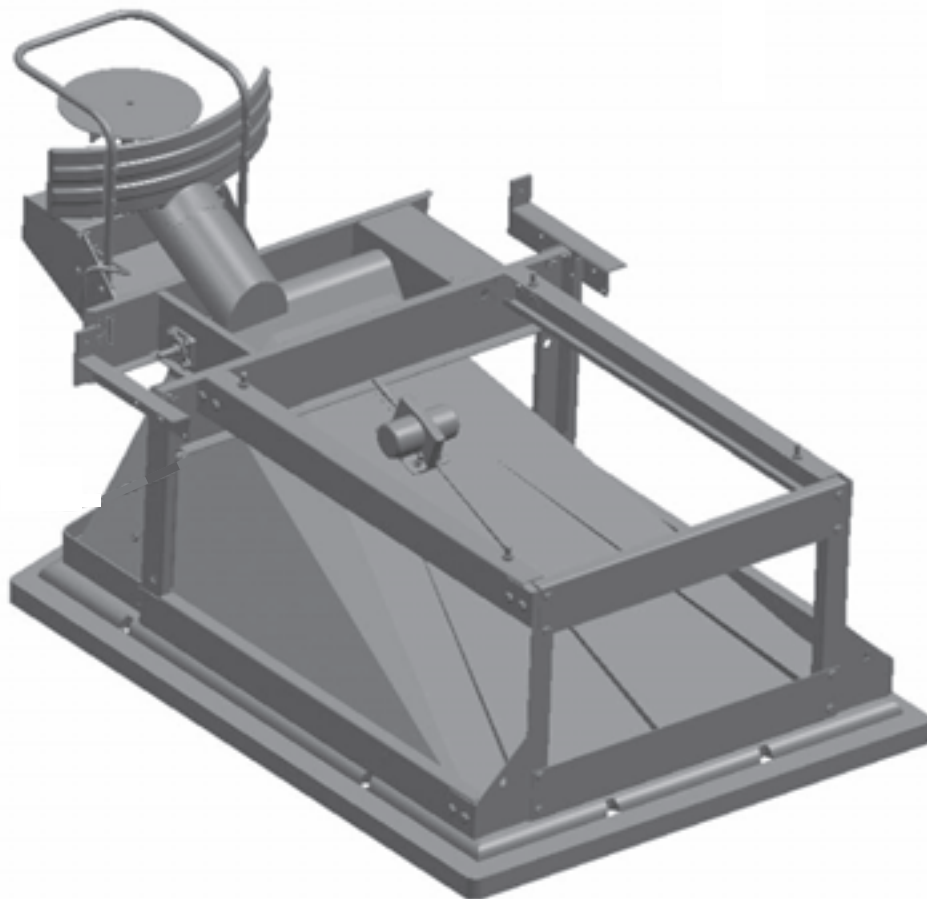
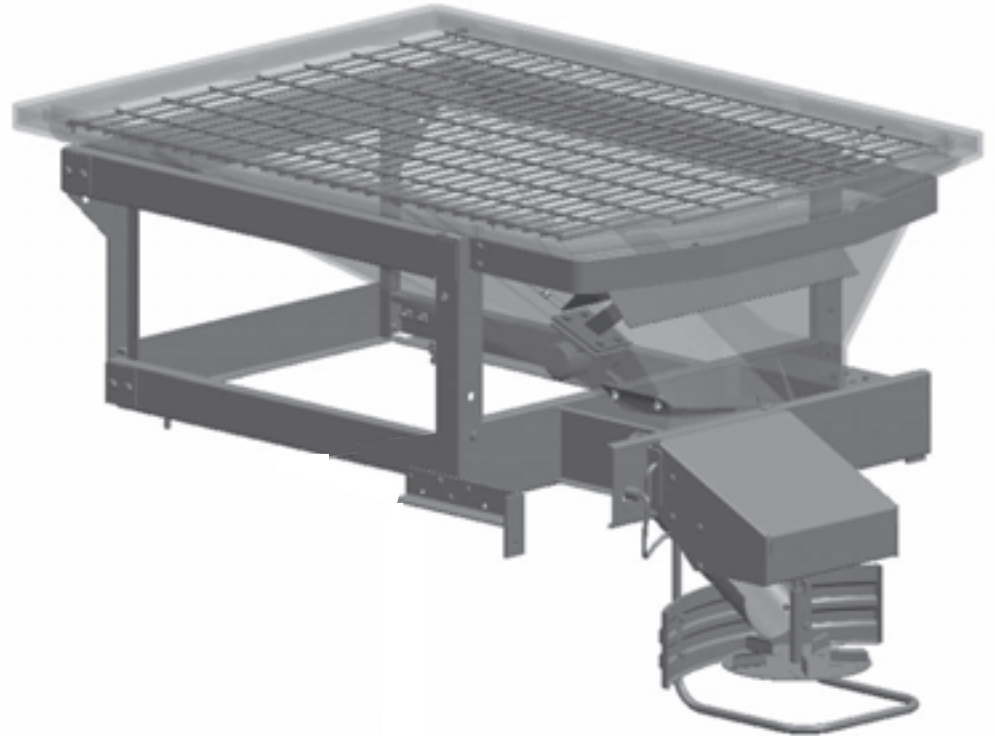

Bulk Material Spreader

Model #MS-2000

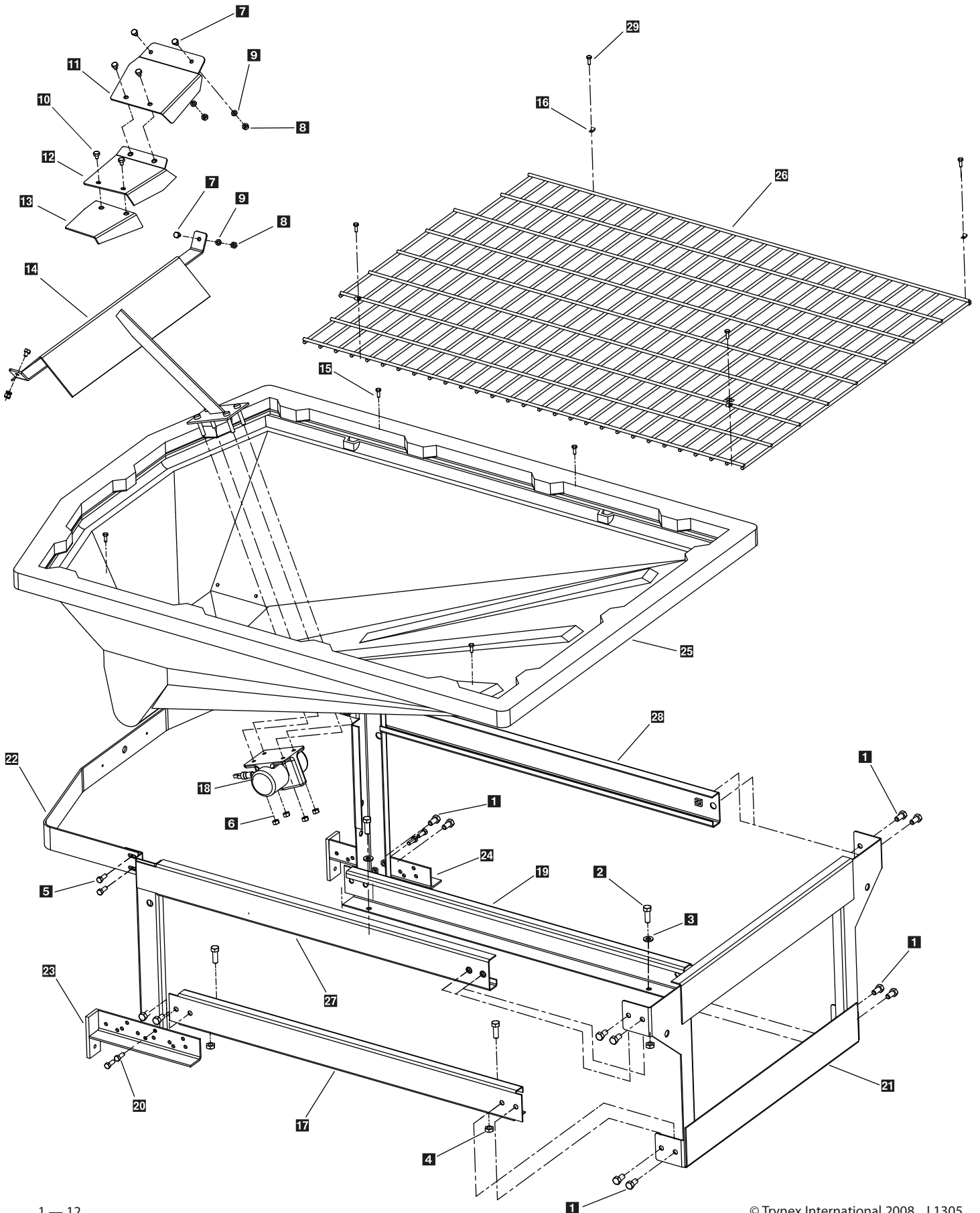

Key	Part No.	Description	Qty.
1	D 6528	1/2" - 13 x 1" Hex Bolt Serrated Head	12
2	D 4116	1/2" - 13 x 1-1/2" Hex Bolt	4
3	D 4119	1/2" Flat Washer	4
4	D 4120	1/2" Lock Nut	4
5	D 6452	3/8" - 16 x 1" Hex Bolt Serrated HWH Type F	4
6	D 6584	3/8" Serrated Lock Nut	4
7	D 6524	5/16" - 18 x 1-1/2" Tap Bolt	4
8	D 6138	5/16" Hex Nut	4
9	D 6165	5/16" Lock Washer	4
10	D 6452	3/8-16 x 1 Serrated Flange	4
11	D 6471	Main Baffle	1
12	D 6472	Second Baffle	1
13	D 6473	Third Baffle	1
14	D 7190	Inverted Vee	1
15	D 6874	#14 x 1-1/4" SS Self Drilling Hex Head TEK Screw	4
16	D 6509	Top Screen Hold Down	4
17	D 7185	Lower Rail Right	1
18	D 6515	Heavy Duty Vibrator	1
19	D 7186	Lower Rail Left	1
20	D 4121	3/8" - 16 x 1" Hex Bolt	4
21	D 7189	Front Frame Weldment	1
22	D 6533	Hopper Apron	1
23	D 6536	Adj. Stop Bracket RT	1
24	D 6537	Adj. Stop Bracket LT	1
25	T 30715	MS-2000 Hopper	1
26	T 30716	Top Screen	1
27	D 7183	2000 Right Frame Weldment	1
28	D 7184	2000 Left Frame Weldment	1
29	D 6553	Top Screen Hold Down Screw	4

MS-2000 Auger Drive Assembly

Parts Breakdown

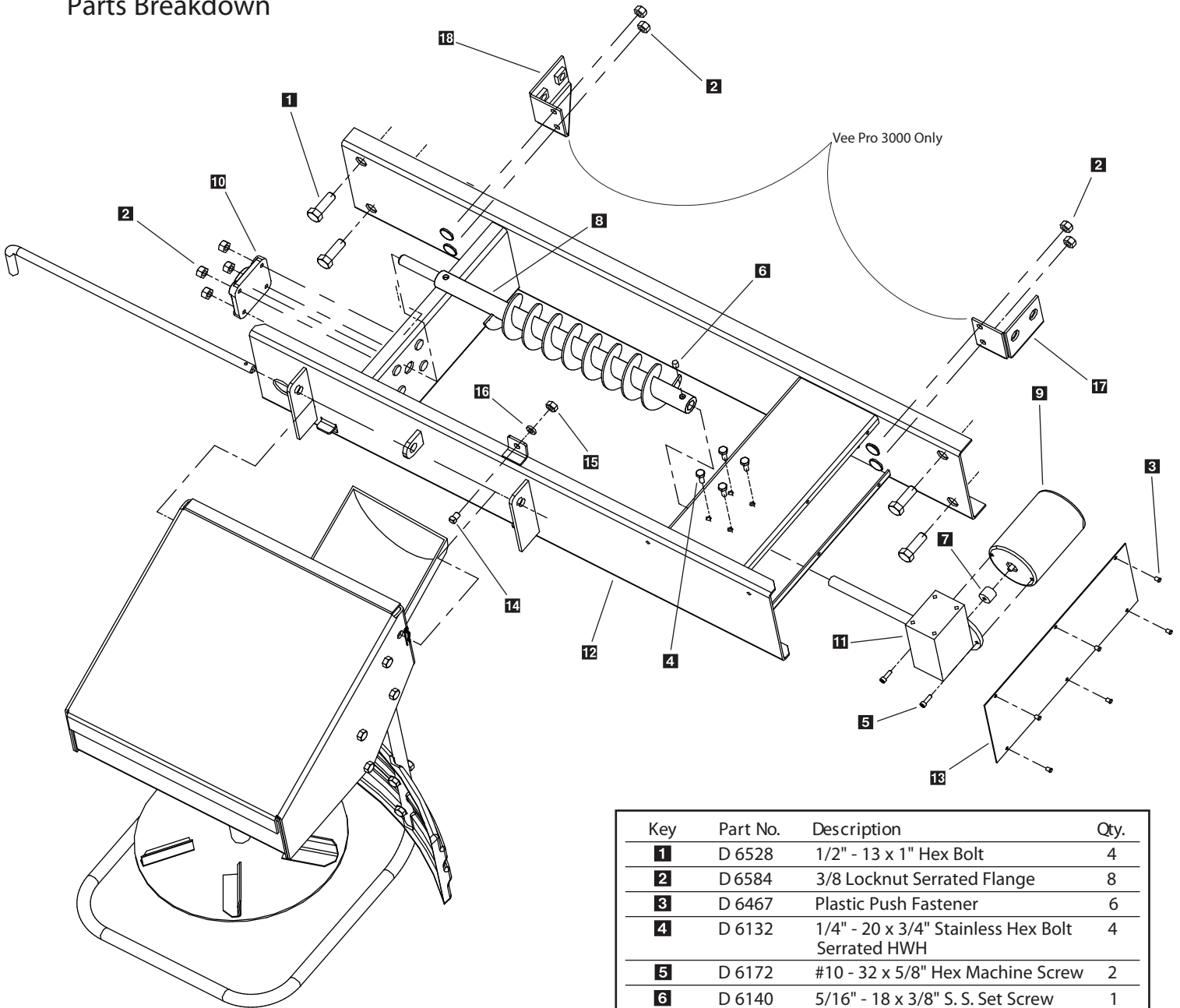

Key	Part No.	Description	Qty.
1	D 6528	1/2" - 13 x 1" Hex Bolt	4
2	D 6584	3/8 Locknut Serrated Flange	8
3	D 6467	Plastic Push Fastener	6
4	D 6132	1/4" - 20 x 3/4" Stainless Hex Bolt Serrated HWH	4
5	D 6172	#10 - 32 x 5/8" Hex Machine Screw	2
6	D 6140	5/16" - 18 x 3/8" S. S. Set Screw	1
7	D 6232	Motor Drive Coupler	1
8	D 6562	20" Auger	1
9	D 6320	Auger Motor	1
10	D 6512	Bearing with Cover	1
11	D 6566	Auger Trans/30:1	1
12	D 6534	VP Auger Drive Weld Assy.	1
13	D 6535	Auger Motor Cover	1
14	D 6524	5/16" - 18 x 1-1/2" Tap Bolt	1
15	D 6138	5/16" Lock Nut	1
16	D 6165	5/16" Flat Washer	1
17	D 6736	3000 Mounting Bracket - Right	1
18	D 6737	3000 Mounting Bracket - Left	1

MS-2000 Spinner Drive Assembly

Parts Breakdown

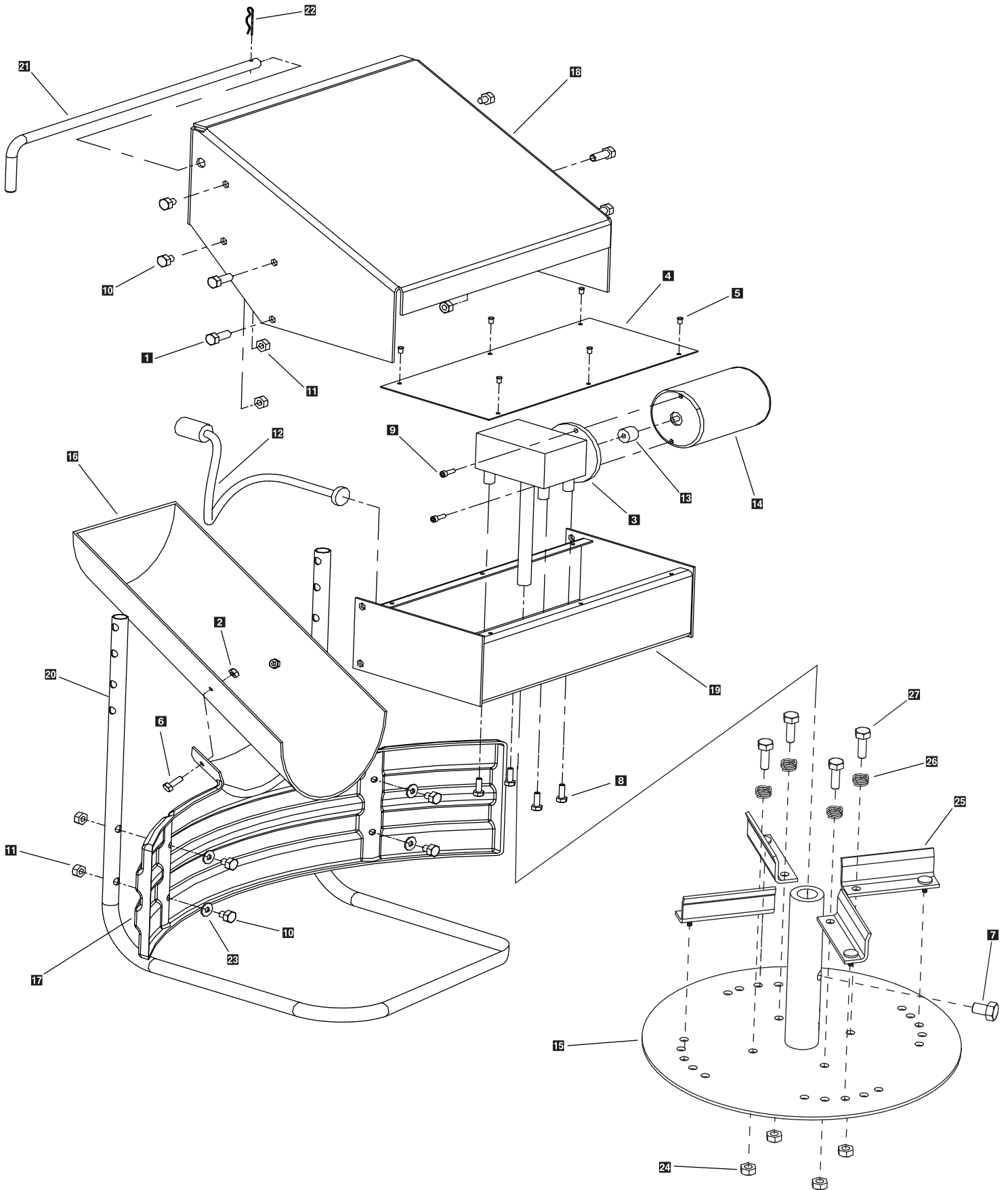

MS-2000 Spinner Drive Assembly

Parts Breakdown



Key	Part No.	Description	Qty.
1	D 6452	3/8" - 16 x 1" Hex Bolt	4
2	D 4289	1/4" Lock Nut	4
3	D 6107	Transmission	1
4	D 6109	Motor Cover	1
5	D 6467	Plastic Push Fastener	6
6	D 6854	1/4" - 20 x 1" Stainless Hex Bolt Flange Head	4
7	D 6133	5/16" - 18 x 1/2 Hex Bolt	1
8	D 6131	1/4" - 20 x 1/2 SS Flange Bolt	4
9	D 6172	#10 - 32 x 5/8" Serrated Flange Bolt	2
10	D 6462	5/16 - 18 x 1-1/2" Bolt	8
11	D 6138	5/16" Lock Nut	10
12	D 6162	24" Power Cable	1
13	D 6232	Motor Drive Coupler	1
14	D 6106	Spinner Motor	1
15	T 30718	12" Spinner w/Extended Shaft	1
16	D 6517	Chute	1
17	D 6564	Deflector	1
18	D 6575	Drive Enclosure Shroud	1
19	D 6541	Spinner Drive Enclosure	1
20	D 6543	Tubular Spinner Guard	1
21	D 6563	Pin	1
22	D 4135	Hair Pin Clip	1
23	D 6165	5/16" Flat Washer	4
24	D 4289	1/4-20 Nylock	4
25	T 30211	Adjustable fin	4
26	T 30217	Tension Spring	4
27	T 30218	1/4-20 x 1-1/4 Panhead MS SS	4

MS-2000 Mounting System

Strapping Techniques

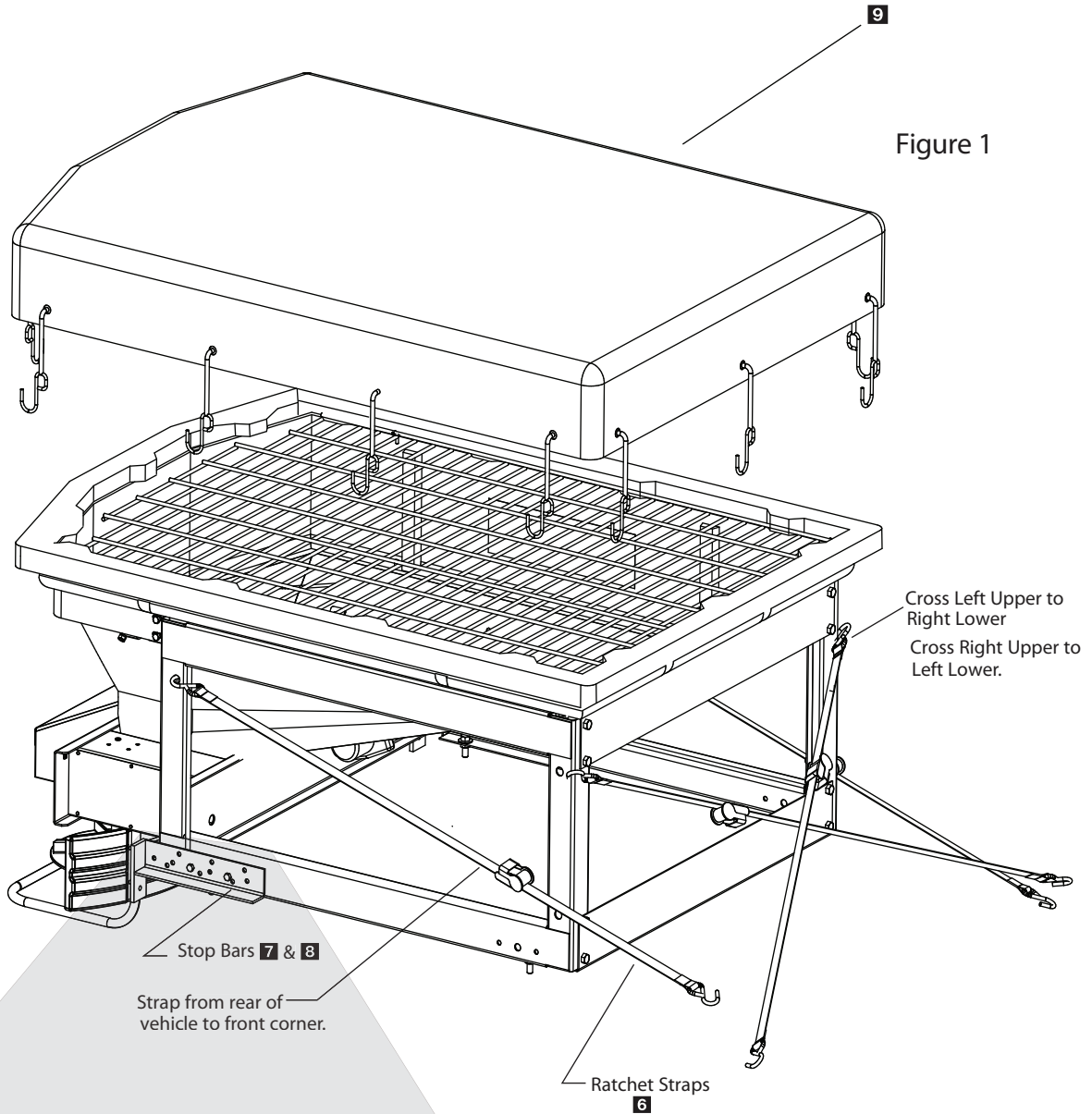
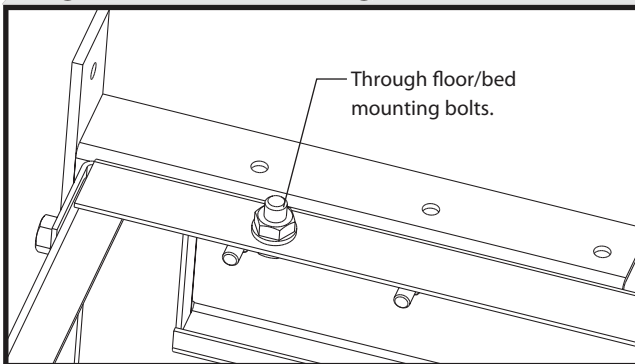
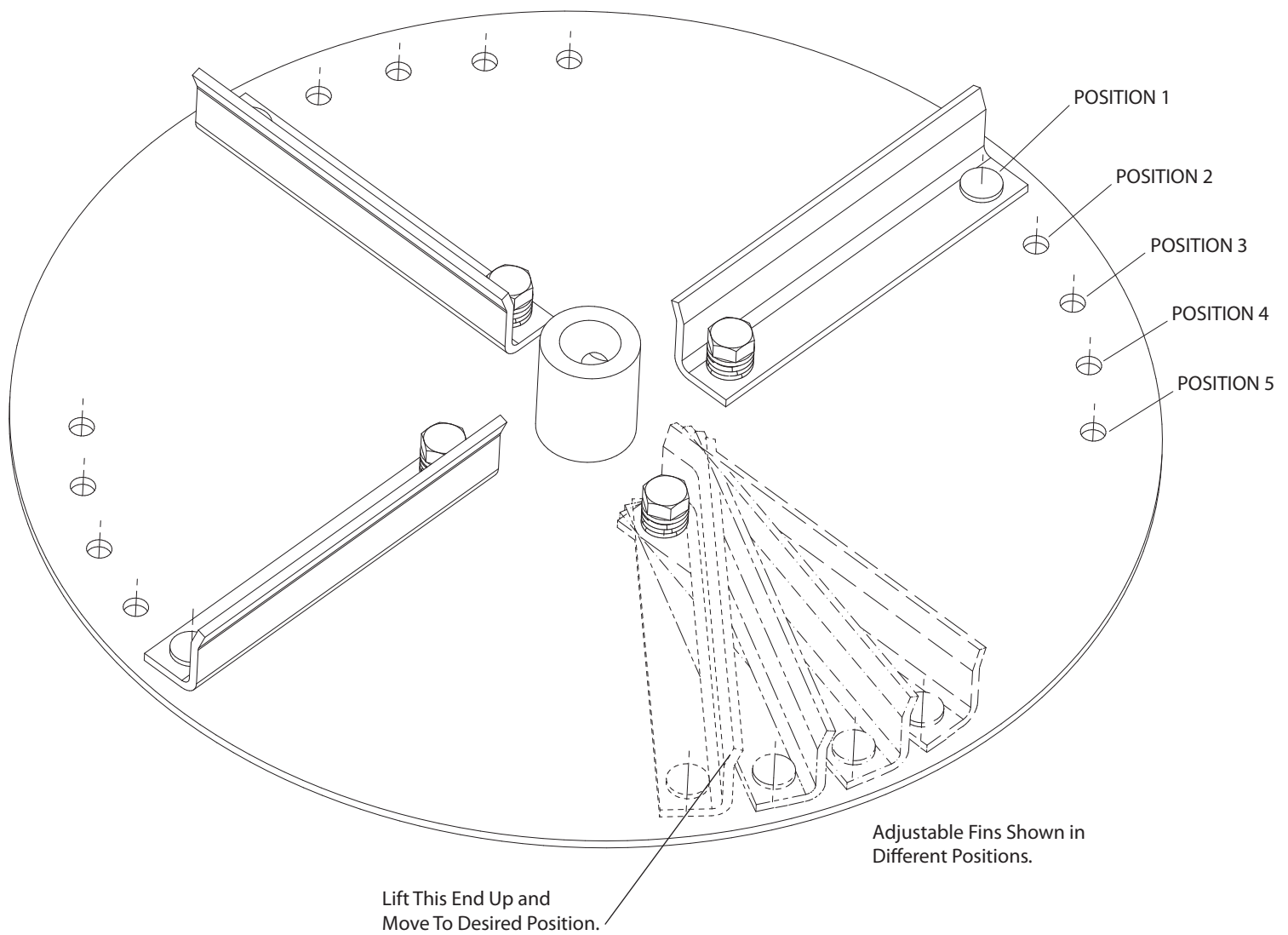

Figure 2: Frame Mounting Bolts



Key	Part No.	Description	Qty.
1	D 4116	1/2" - 13 x 1-1/2" Hex Bolt	4
2	D 4119	1/2" Flat Washer	4
3	D 4120	1/2" Lock Nut	4
4	D 4121	3/8" - 16 x 1" Hex Bolt	4
5	D 4124	3/8" Lock Nut	4
6	D 6503	Ratchet Strap	4
7	D 6536	Adj. Stop Bracket RT	1
8	D 6537	Adj. Stop Bracket LT	1
9	T 30717	MS-2000 Tarp	1



The purpose of the adjustable fin is to provide a way to adjust spread patterns with different materials. You can select the desired position by simply lifting up on the outside top edge. You will notice that different materials act in different ways in relation to spinner speed. By moving the fins you will be able to correct most pattern issues without having to sacrifice spinner speed. All adjustments should be made on pavement and positions noted for future reference, this process should be incorporated into your normal calibration process.

MS-1875 Gate Exploded View

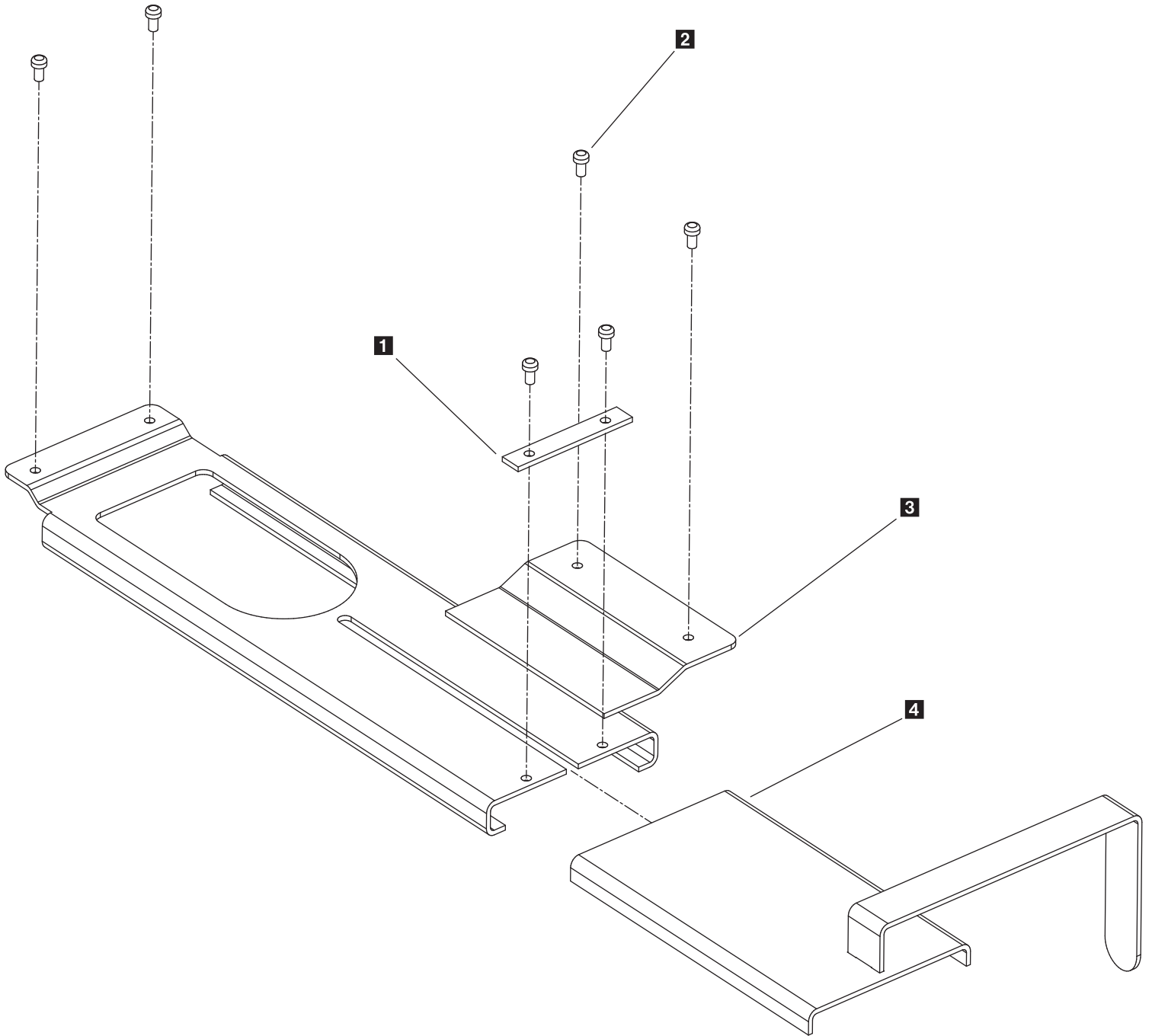

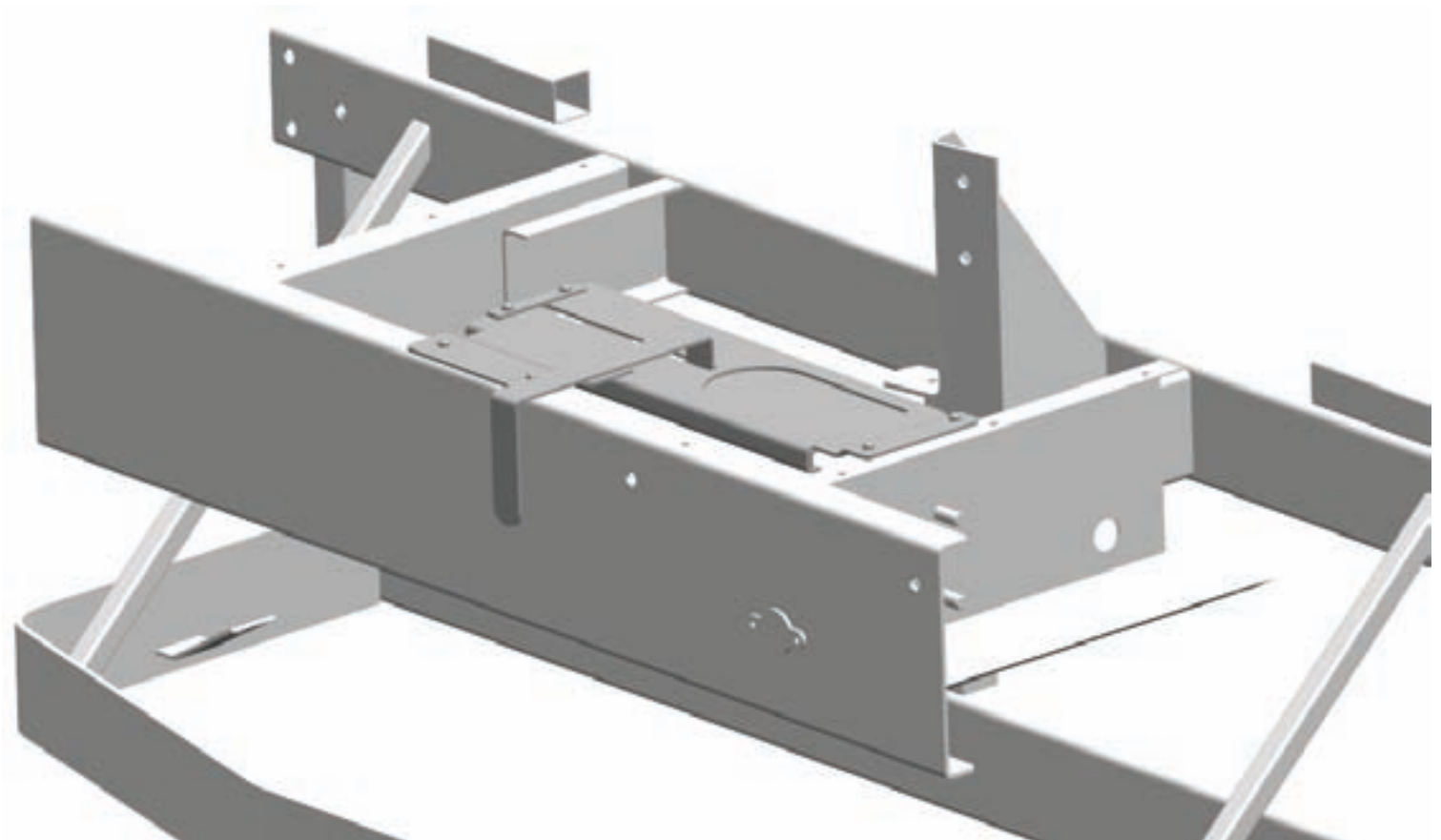

Key	Part No.	Description	Qty.
1	T 30711	Gate Slide Stop	1
2	D 6130	3/16 Aluminum Rivet	6
3	T 30709	Main Gate Body	1
4	T 30710	Gate Slide	1

MS-2000 Gate Exploded View

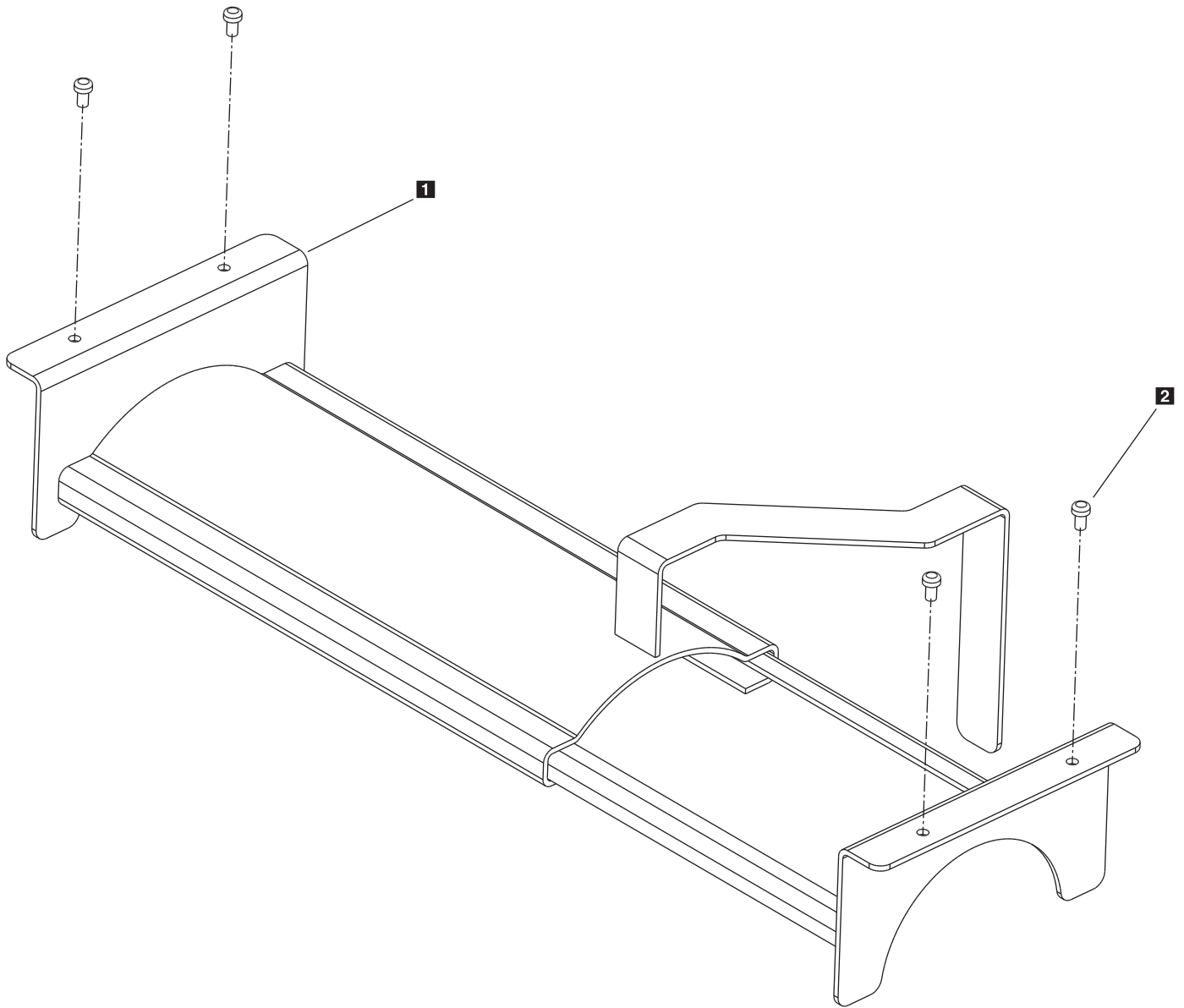

Key	Part No.	Description	Qty.
1	T 30719	Welded Gate Assembly	1
2	D 6130	3/16 Aluminum Rivet	4

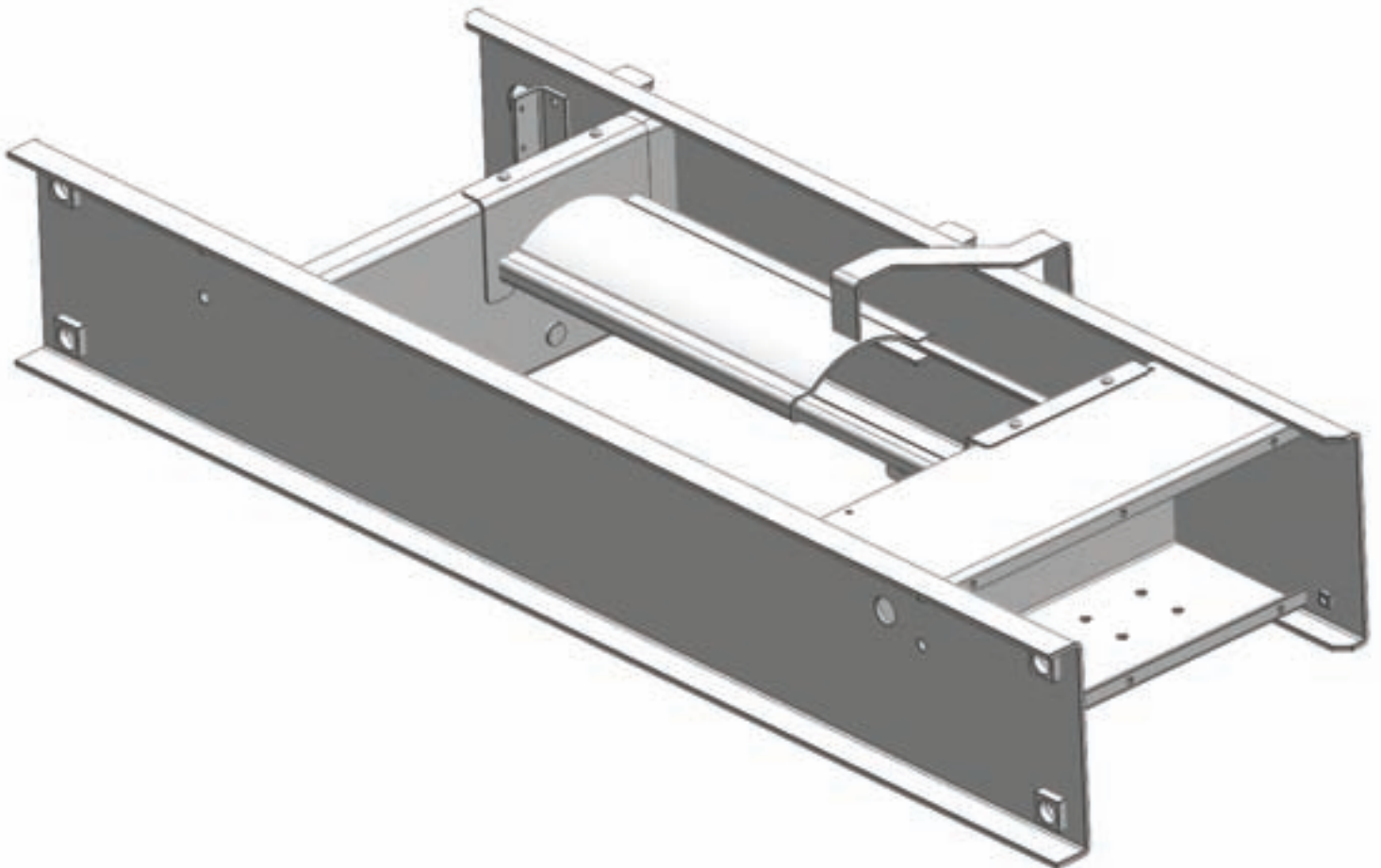

Key	Part No.	Description	Qty.
1	T 30719	Welded Gate Assembly	1
2	D 6130	3/16 Aluminum Rivet	4

Step 1: Take harness assembly and route from the rear of the vehicle to the front. Route harness along frame and attach to frame holes and frame supports. It is not recommended to attach to fuel or brake lines for obvious reasons. Do not route close to exhaust system or engine, even though Snowex uses high temperature wiring, it still could melt under extreme heat and short the spreader electrical system, as well as the vehicle electrical system.

Step 2: Mount rear plug on bumper using supplied bolts, locate towards the center of the bumper to reduce the amount of debris the tires will throw to the rear. Important: Apply a small amount of dielectric grease to the plug. Also try to mount so plug faces upward to help keep plugs tightly sealed.

Step 3: Secure harness from the rear to the front using heavy duty ty-wraps or frame clips along the frame and lighter duty ty-wraps everywhere else.

Step 4: Layout harness portion that connects to the battery along the fire wall and fender well. Do not connect power leads to battery yet. Drill a 3/4" hole in the fire wall, or use existing access hole, for the control portion of the harness and route connector and harness through hole. Be sure to check the area on the other side of the fire wall to make sure you are not going to drill into the vehicle harness or a control module. Generally you can drill on either side of the steering wheel for a good location.

Step 4A: The power harness from control box to battery will need to be routed from the inside of the cab to the battery – this results from the large high amperage connector. Route leads with lugs to battery — do not connect power at this time.

Step 5: Connect harness to the back of the controller and mount to a suitable location. NOTE: You may want to contact customer before mounting controller, some prefer not to have holes drilled into the dashboard. Ty-wrap loose controller harness and move to the engine compartment. Do not mount close to any heater vents.

Step 6: Connect power leads to the battery: Red + Positive, Black – Negative, always connect to the primary battery if using a dual battery system, secure loose loom to any other large or medium vehicle harness with medium duty ty-wraps this will secure wiring harness.

Step 7: Push the ON/OFF button on the controller to check for power, when that has been confirmed turn power **OFF**. The electrical portion of the installation is complete.

MS-1875 Electrical System

Electrical System

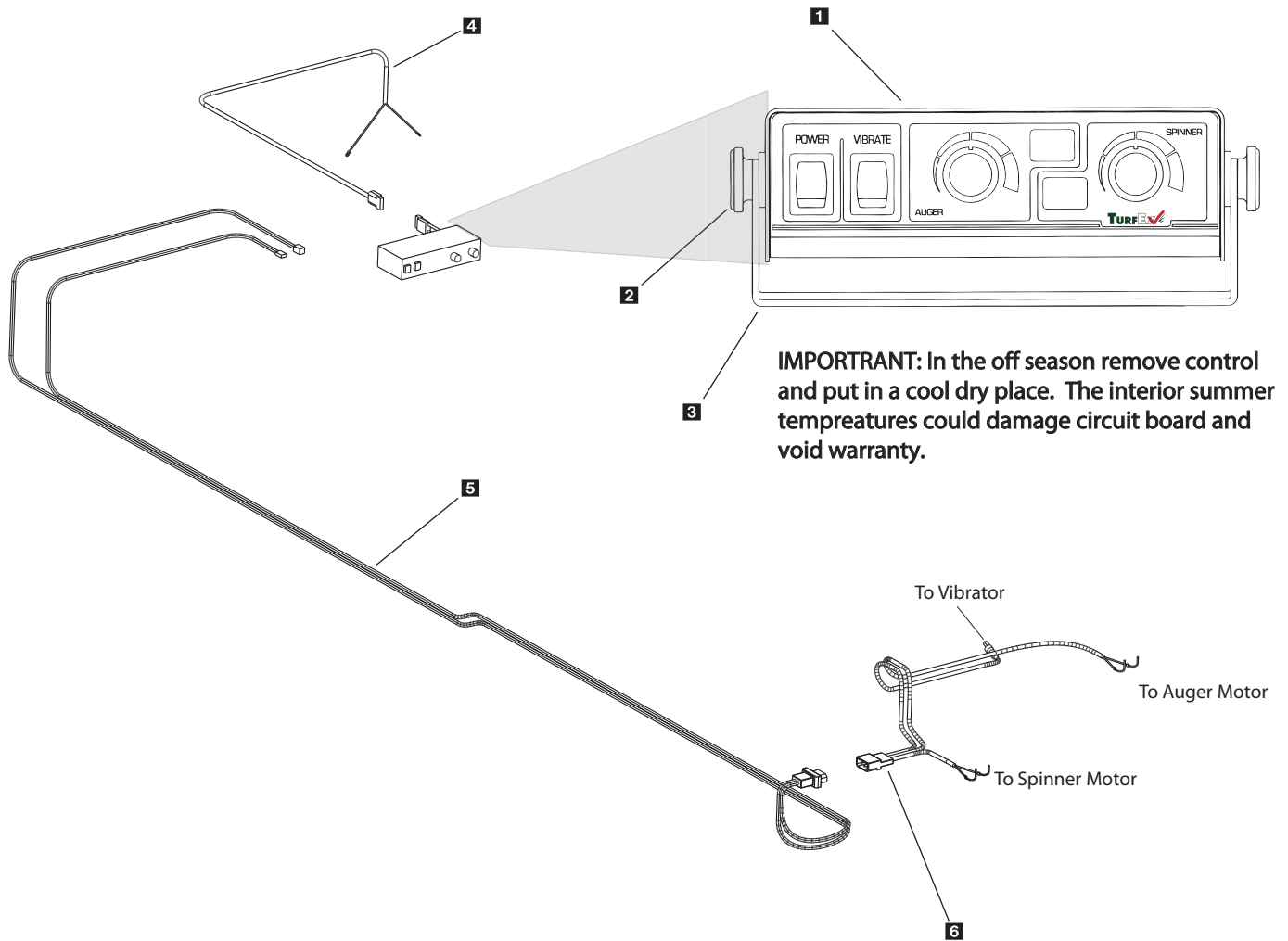

Special Notes:

1. All external connections must have dielectric grease.
2. Read lead labels before attaching to power source or ground.
3. No other devices may be spliced into wiring harness.
4. Any repairs to wiring harness must be done with heat shrink butt connectors.
5. If inline fuse is installed, use a 60 amp maxi fuse or circuit breaker.

Key	Part No.	Description	Qty.
1	D 6527	MS-1875 Controller	1
2	D 6124	Bracket Knob	2
3	D 6329	Controller Bracket	1
4	D 6341	Control Power Cable	1
5	D 6322	Wiring Harness - 25'	1
6	D 6321	Power Cord - 48"	1
	D 6118	Dust Cover (not shown)	1
	D 6344	Dielectric Grease - 1 1/2 oz. (not shown)	1

MS-2000 Electrical System

Parts Breakdown

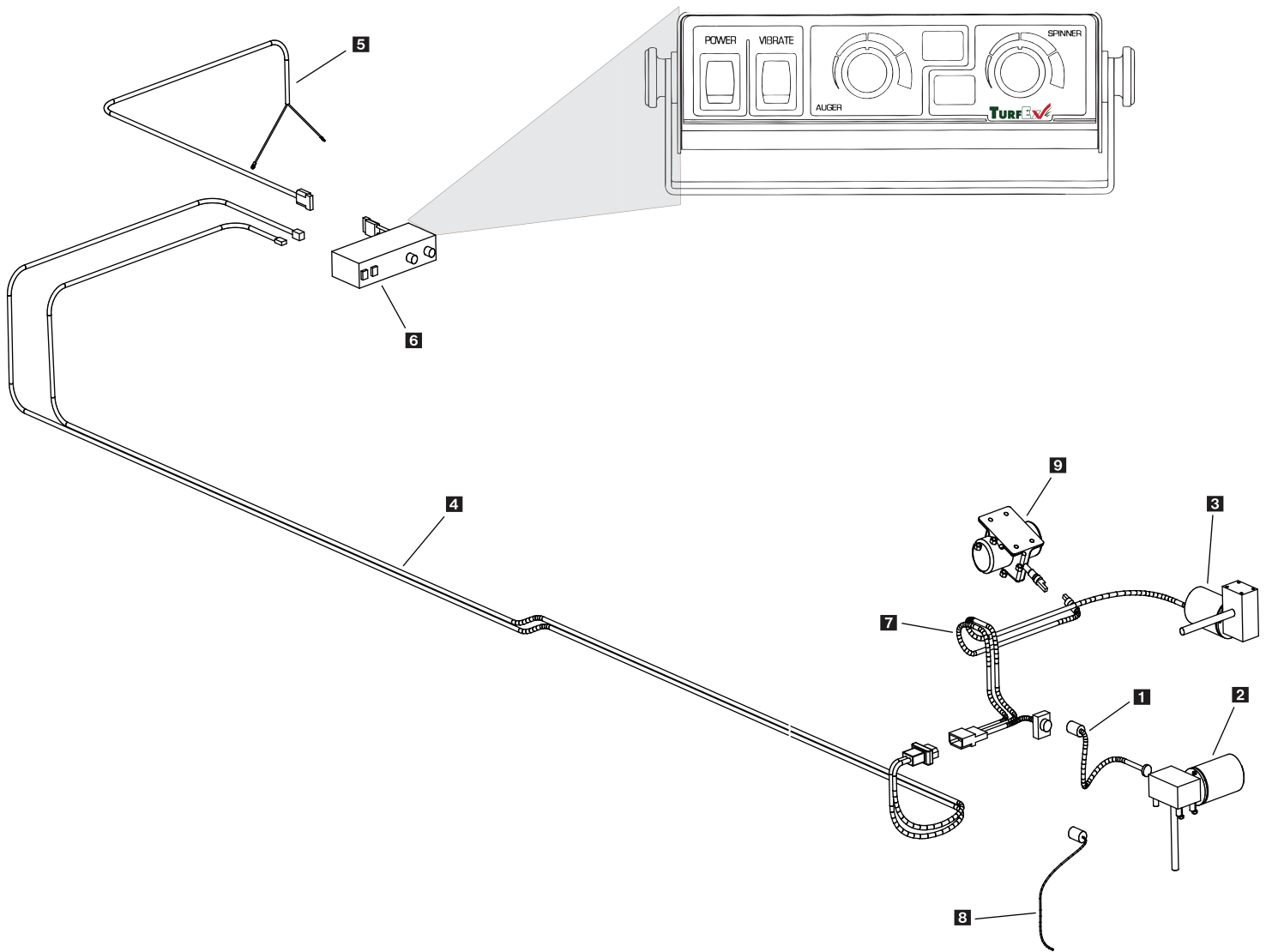

Special Notes:

1. All external connections must have dielectric grease.
2. Read lead labels before attaching to power source or ground.
3. No other devices may be spliced into wiring harness.
4. Any repairs to wiring harness must be done with heat shrink butt connectors.
5. If inline fuse is installed, use a 60 amp maxi fuse or circuit breaker.

Key	Part No.	Description	Qty.
1	D 6162	Power Cable	1
2	D 6106	Spinner Motor	1
3	D 6320	Auger Motor	1
4	D 7216	Vehicle Harness - 25'	1
5	D 6341	Control Power Cable	1
6	D 7240	Controller	1
7	D 6511	Power Cord - 54"	1
8	D 6515	Heavy Duty Vibrator	1
9	D 6118	Dust Cap	1

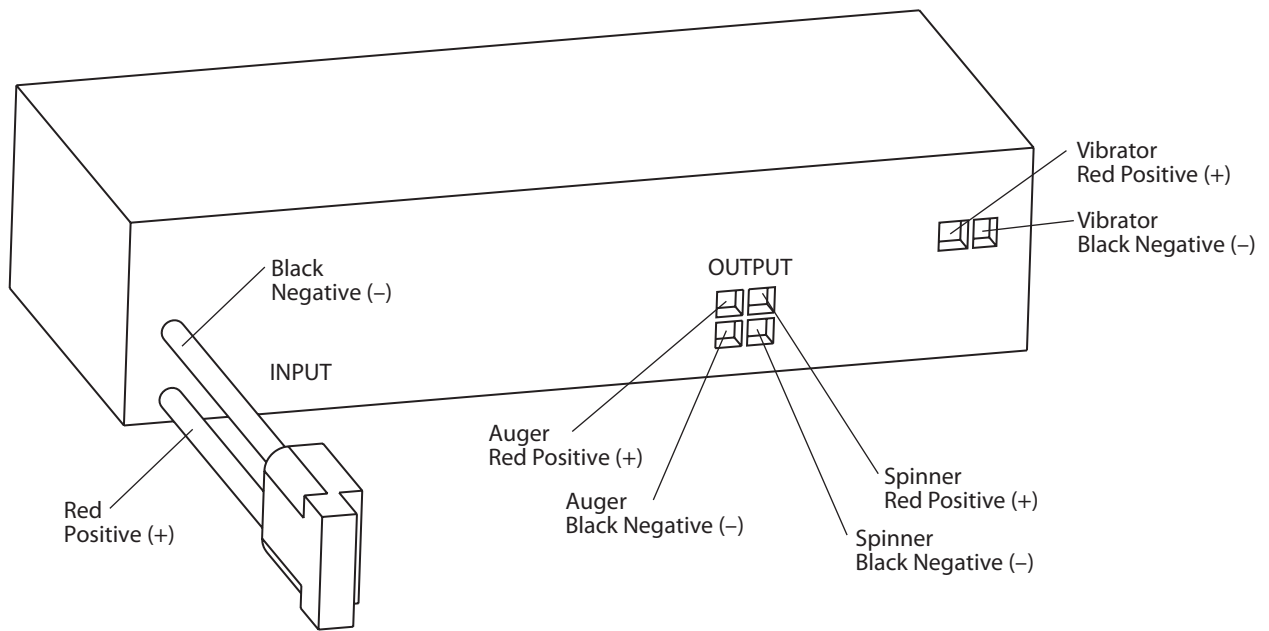

D6341 Control Power Cable

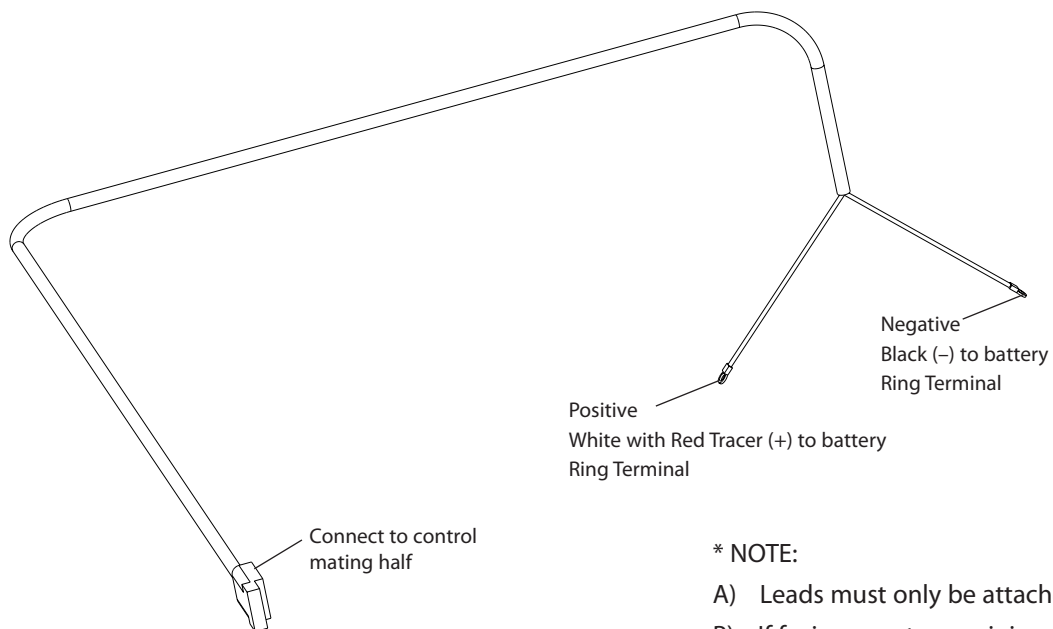

*** NOTE:**

- A) Leads must only be attached to battery.
- B) If fusing, must use minimum 60 Amp Maxi type fuse or circuit breaker.

D6511 Spreader Power Harness

Circuit Diagram

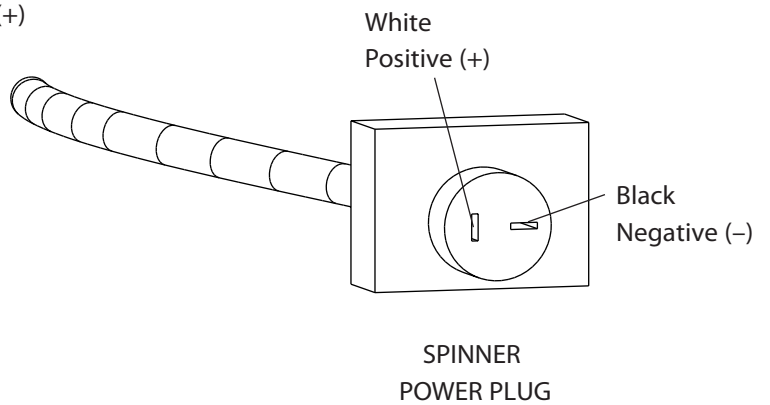
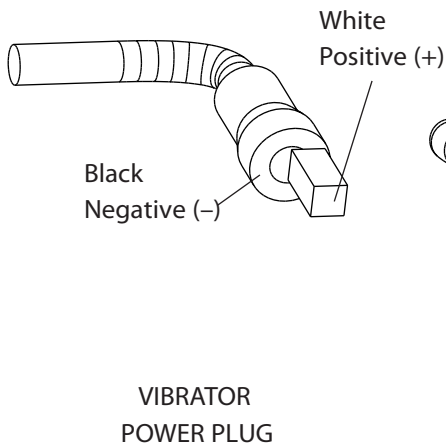
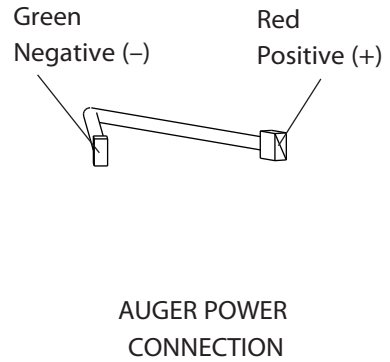
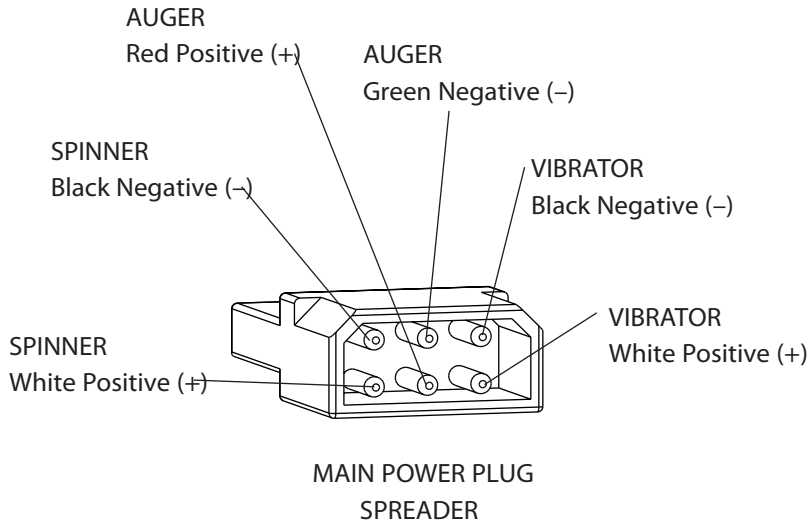

* NOTE: Plug has polarity reversed for proper motor rotation

D6322 Vehicle Harness Circuit Diagram

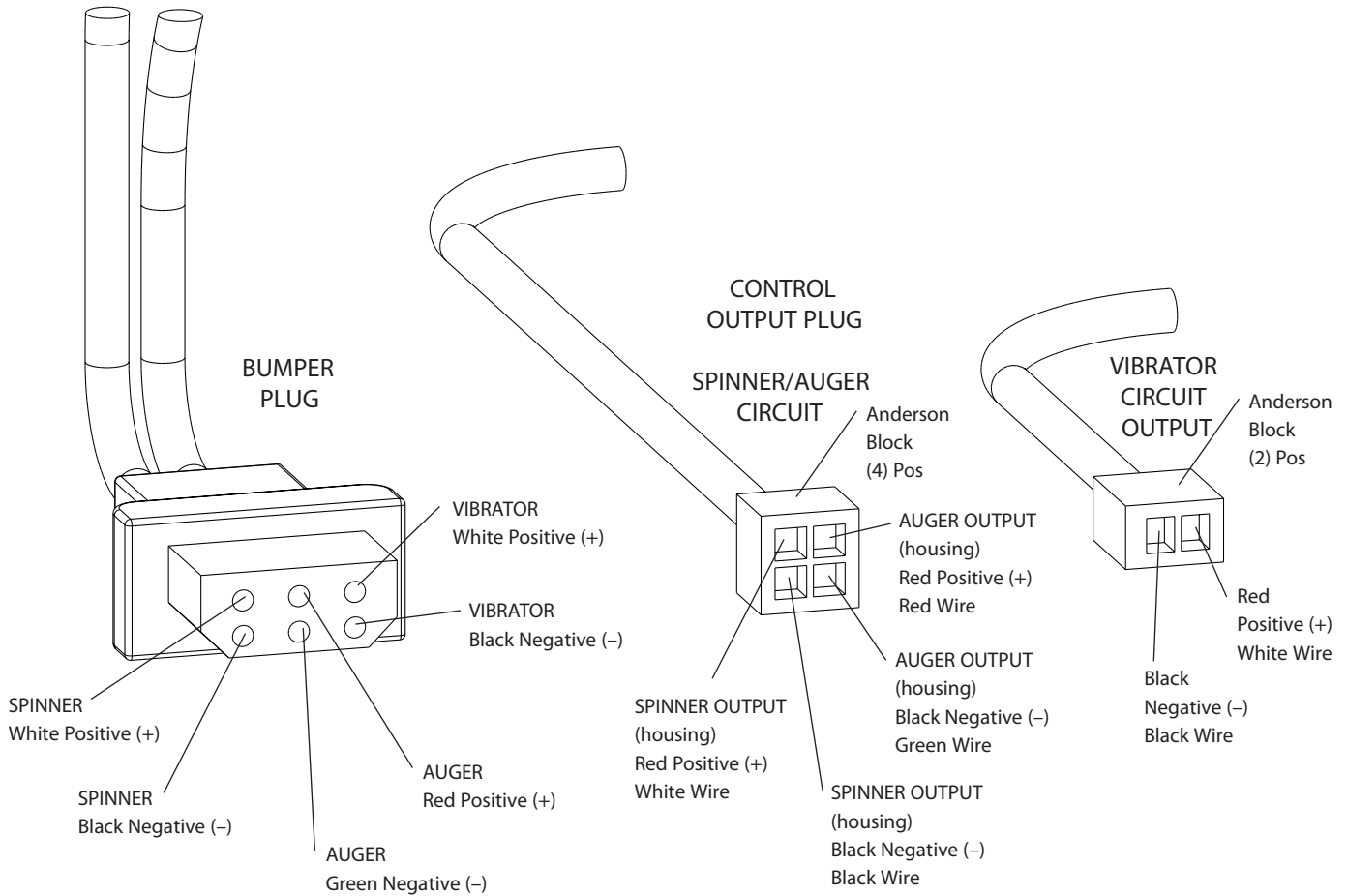

* NOTE: Reference Bumper Plug for Color Code

MS-2000 Bulk Material Spreader



Mounting Instructions

Step 1: Remove tailgate from pickup bed.

Step 2: Load spreader on to truck bed and mount spinner assembly.

Step 3: Slide spreader forward until deflector/chute assembly makes contact with vehicle. Then, slide spreader back approx. 1" to allow proper clearance.

Step 4: Install stop bars using supplied hole patterns (see Fig.2). To achieve the best position, you may need to drill additional holes in bracket in order to properly position spreader.

Step 5: Now that the spreader is located front to back, you will now center it left to right. Looking at the inside front and rear corner area of the lower frame area, you will notice (4) holes in the bottom of the frame. Using a paint pen or similar marking device, mark hole locations.

Step 6: Before drilling holes, look beneath the approximate area where each hole will be located. Make sure there are no vehicle components that will be in the path of the drill before doing this step. If there are interferences, you can relocate holes as making sure there are at least two forward and two rearward of the front to back centerline.

Step 7: Install and tighten all (4) bolts.

Step 8: Install ratchet straps (See MS-2000 Mounting System: Strapping Techniques). It is very important for everyone's safety this strapping method be used as the standard mounting procedure.

(Do not use ratchet straps exclusively.)

Step 9: Connect the spreader power cord to vehicle main power plug mounted at rear of vehicle (see Electrical Installation).

Step 10: Connect Center High Mount Stop Lamp (CHMSL) cord from the spreader to mating half attached to vehicle (see Electrical Installation).

MS-1875 Bulk Material Spreader



Mounting Instructions For TPM-275

- Step 1: Install clevis weldment **1** in center of upper rail as shown. Drill two 3/8 inch clearance holes in upper rail and fasten using 3/8-16 x 2 inch hex bolts with locking nuts provided.
- Step 2: Install four channel weldments **2** in ends of upper and lower rails as shown. Fasten in four places using 3/8-16 x 2" hex bolts along with locking nuts provided. Drill and bolt four holes (do not tighten yet).
- Step 3: Install two upright /legs **5** into channel weldments as shown. Fasten with 3/8-16 x 3-1/4 inch hex bolts along with washers and locking nuts provided.
- Step 4: Tighten all hardware.
- Step 5: Install and tighten lift arm pins **9** as shown in illustration.
- Step 6: Install unit on any category one tractor mount.

TPM-275

Parts Breakdown

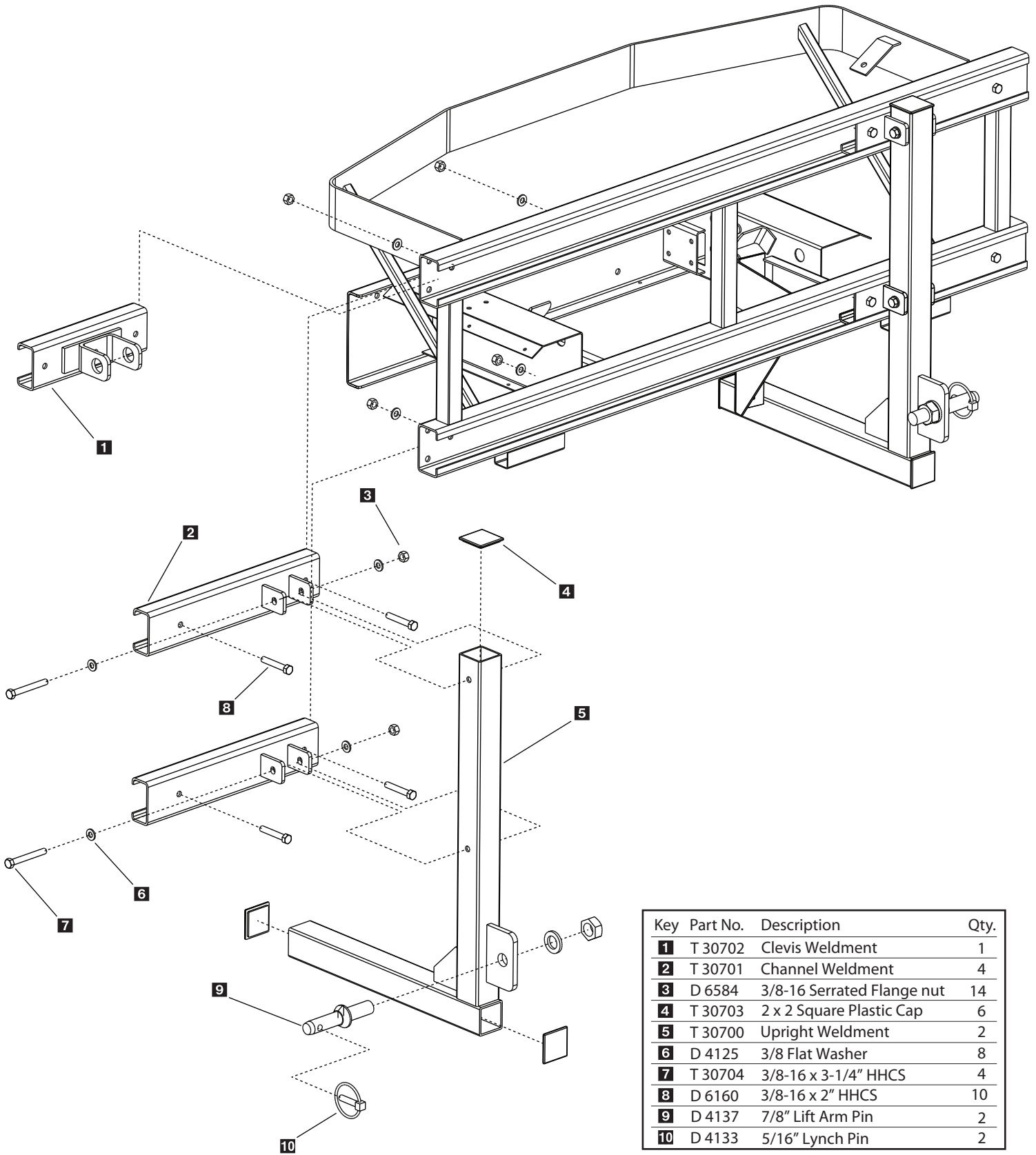

Key	Part No.	Description	Qty.
1	T 30702	Clevis Weldment	1
2	T 30701	Channel Weldment	4
3	D 6584	3/8-16 Serrated Flange nut	14
4	T 30703	2 x 2 Square Plastic Cap	6
5	T 30700	Upright Weldment	2
6	D 4125	3/8 Flat Washer	8
7	T 30704	3/8-16 x 3-1/4" HHCS	4
8	D 6160	3/8-16 x 2" HHCS	10
9	D 4137	7/8" Lift Arm Pin	2
10	D 4133	5/16" Lynch Pin	2

- **WARNING** – When servicing is necessary, perform it in a protected area. Do not use power tools in rain or snow because of danger of electrical shock or injury. Keep area well lighted. Use proper tools. Keep the area of service clean to help avoid accidents.
- **WARNING** – Disconnect electricity to spreader before servicing.
- **CAUTION** – The controller is a solid state electronic unit and is not serviceable. Any attempt to service will void warranty.
- **CAUTION** – There are no serviceable parts in the motor/transmission assembly. Any attempt to service will void warranty.
- **CAUTION** – When replacing parts use only original manufacturer's parts. Failure to do so will void warranty.
- Use di-electric grease on all electrical connections to prevent corrosion at the beginning and end of the season and each time plugs are disconnected.
- Gently wash unit after each use to prevent material build-up and corrosion.
- **CAUTION** – When pressure washing motor enclosure area stay at least 36" away from all electrical items.
- Paint or oil all bare metal surfaces at the end of the season.
- Apply small amount of light oil to latches as needed.
- If motor cover is removed for any reason, use silicone sealant to ensure weather proofing of enclosure.
- Grease bearings after every 20 hours use.
- After first use, tighten all nuts and bolts on spreader and mount.
- **WARNING:** Never remove spreader with material in hopper.

Adjustable Baffle Kit #ABK-020

For MS-2000 Bulk Material Spreader



- 1 D-6497 (first stage) is for wet sand/wet salt/or a wet blended mix.
- 2 D-6498 (second stage) attached to the first stage; is for dry coarse free flowing materials.
- 3 D-6499 (final stage) attached to the second and first stage; is for fine materials or ice melters.

Key	Part No.	Description	Qty.
1	D 6471	Baffle 1 (wet material)	1
2	D 6472	Baffle 2 (dry coarse material)	1
3	D 6473	Baffle 3 (fine material)	1
4	D 6524	5/16"-18 x 1-1/2" Tap Bolt	2
5	D 6165	5/16" Flat Washer	2
6	D 6138	5/16"-18 Lock Nut	2
7	D 6452	3/8-16 x 1 Serrated Flange Bolt	4

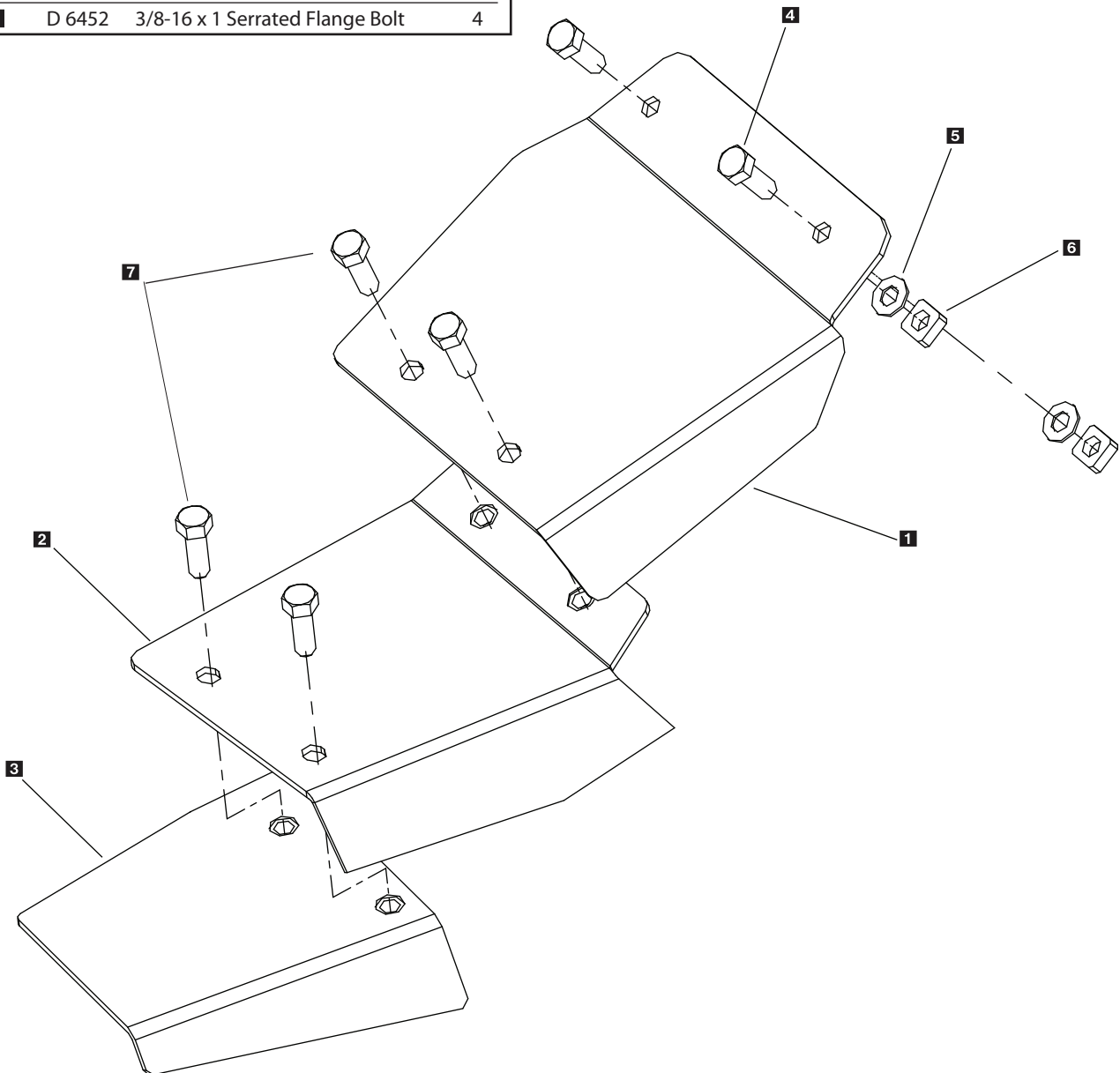

WARNING PROTECTION

- If audible beeping occurs, read display to identify problem. If display reads "OL" (overload) or "OH" (overheat). Shut controller down and carefully clear jammed auger. If display reads "E1" this means there is a dead short in system. Do not use until problem is corrected. If display reads "E 0" this means that the motor is not getting any power. Check all connections. If display reads "LB" the vehicle battery is extremely low (possibly caused by a poor or corroded connection) and could damage the system.
- If there are any problems while operating the spreader, refer to Troubleshooting Guide.

THIS PAGE INTENTIONALLY LEFT BLANK



THIS PAGE INTENTIONALLY LEFT BLANK

Determining Vehicle Payload

Material Type	Example: Coarse Salt – Dry				
Equipment installed when vehicle was weighed	MS-2000				
Front Gross Axle Weight Rating (RGAWR)					
Rear Vehicle Weight Rating (GVWR) (lb.)	8600				
Gross Vehicle Weight (GVW) (lb.) (empty)	– 6500	–	–	–	–
Payload Available (lb.)	= 2100	=	=	=	=
Material Weight (lb./cu. yd.)	÷ 1431	÷	÷	÷	÷
Maximum Volume (cu. yd.)	= 1.47	=	=	=	=
Maximum Height (approximate) (in.)	24"				
Loaded Front Gross Axle Weight (FGAW) (lb.)					
Loaded Rear Gross Axle Weight (RGAW) (lb.)					
Loaded Gross Vehicle Weight (GVW) (lb.)					

Torque Chart

When tightening fasteners, refer to the Torque Chart below for the recommended fastener torque values.

Recommended Fastener Torque Chart (ft.-lb.)			
SIZE	 SAE Grade 2	 SAE Grade 5	 SAE Grade 8
1/4-20	6	9	13
5/16-18	11	18	28
3/8-16	19	31	46
3/8-24	24	46	68
7/16-14	30	50	75
1/2-13	45	75	115
9/16-12	66	110	165
5/8-11	93	150	225
3/4-10	150	250	370
7/8-9	202	378	591
1-8	300	583	893

Metric Grade 8.8 (ft.-lb.)			
SIZE	TORQUE	SIZE	TORQUE
M 6	7	M 12	60
M 8	17	M 14	95
M 10	35	M 16	155

These torque values apply to mount assembly fasteners except those noted in the instruction.

Whenever service is necessary, your local TurfEx Dealer knows your Spreader best. Take your Spreader to your local dealer for any maintenance or service needs on your unit. If this is not possible, the Troubleshooting Guide below may assist you in identifying the problem.

Warning: First read all warning instructions and safety messages before servicing your spreader.

Preliminary Checks

- Be sure all electrical connections are tight and clean.
- Be sure nothing is jammed in the hopper.

PROBLEM	POSSIBLE CAUSE	SOLUTION
Motor doesn't run.	Loose electrical connections.	Check all connections.
	Blown Fuse.	Replace fuse.
	Motor Seized.	Replace motor.
Controller shut down.	Jammed auger.	Carefully clear jammed material.
	Poor electrical connections.	Clean or replace connectors. Use dielectric grease.
	Electrical short.	Check electrical connections. Check for bare wires.
	Controller failure.	Replace controller.
Material not flowing from hopper.	Empty hopper.	Fill hopper.
	Wet material.	Replace with dry material.
	Frozen or coarse material.	Replace material.
	Spinner not turning.	Check drive assembly.
	Auger loose on shaft.	Tighten locking bolt on the side of the auger. There is a flat machined on the driver shaft. Align the auger with this flat and tighten the bolt.
	Vibrator not working.	Replace vibrator
Audible alarm beeping and display shows OL or OH.	Jammed auger, overload shut down.	Turn off for three seconds, then restart. If shut down continues, turn off controller. Clear debris and lumps from auger areas.
Audible alarm beeping display shows E1.	Short in system.	Turn off. Do not use until problem is corrected.
Audible alarm beeping display shows EO.	Motor is not getting power.	Turn off. Check all connections.
Audible alarm beeping display shows LB.	Vehicle battery is extremely low, or a poor connection exists.	Turn off. Charge battery.

Troubleshooting

MS-1875 & MS-2000

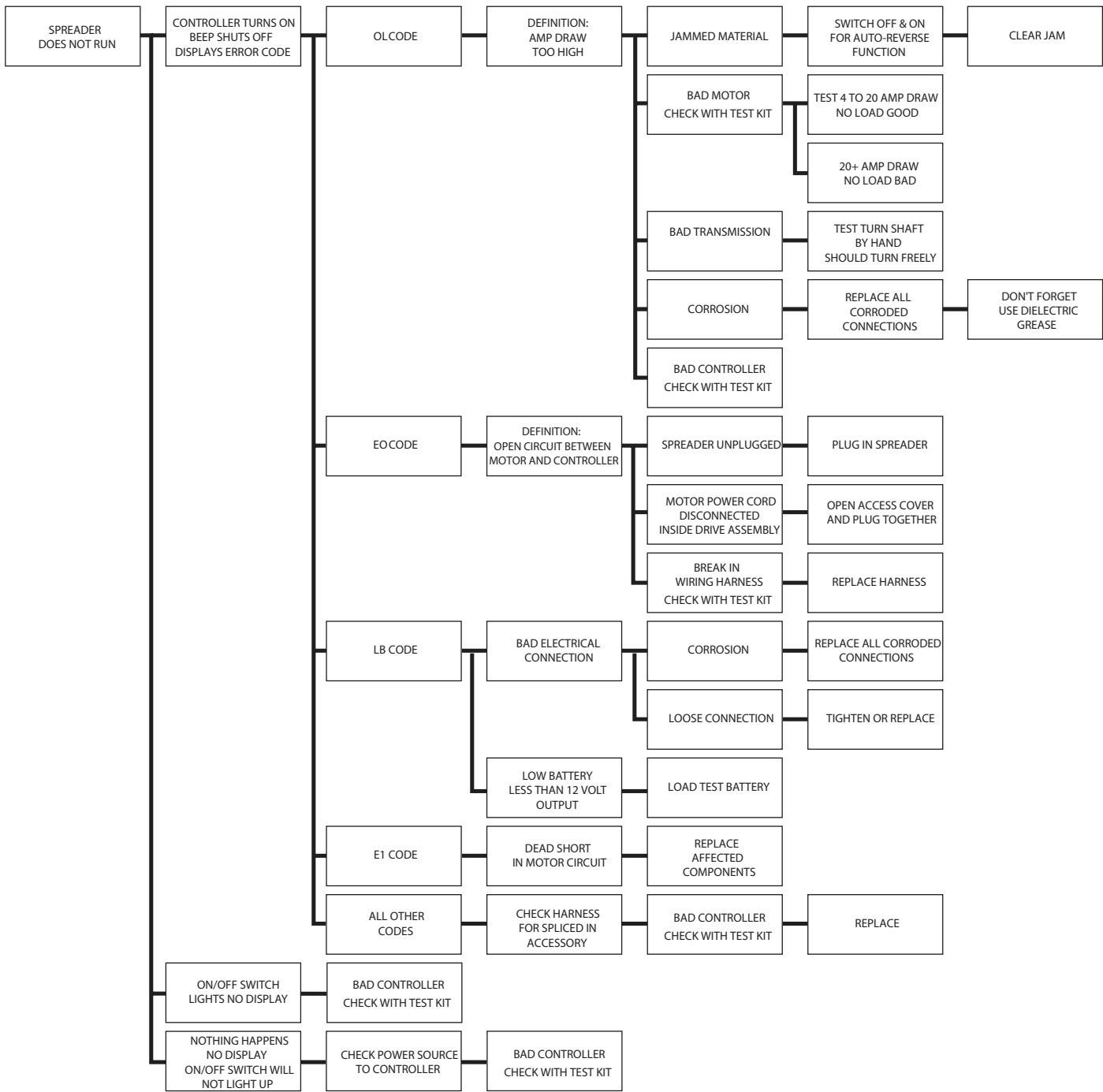

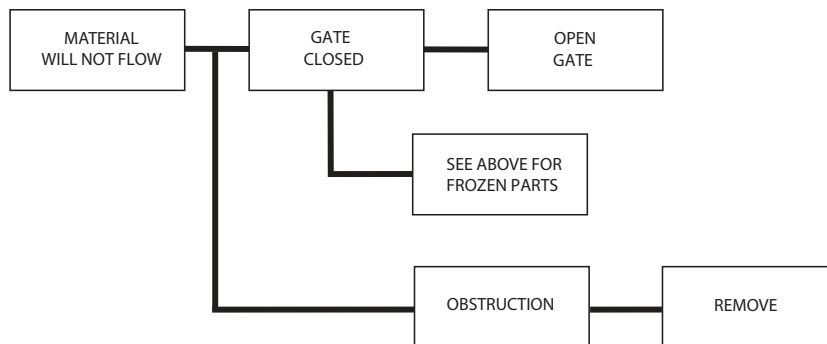
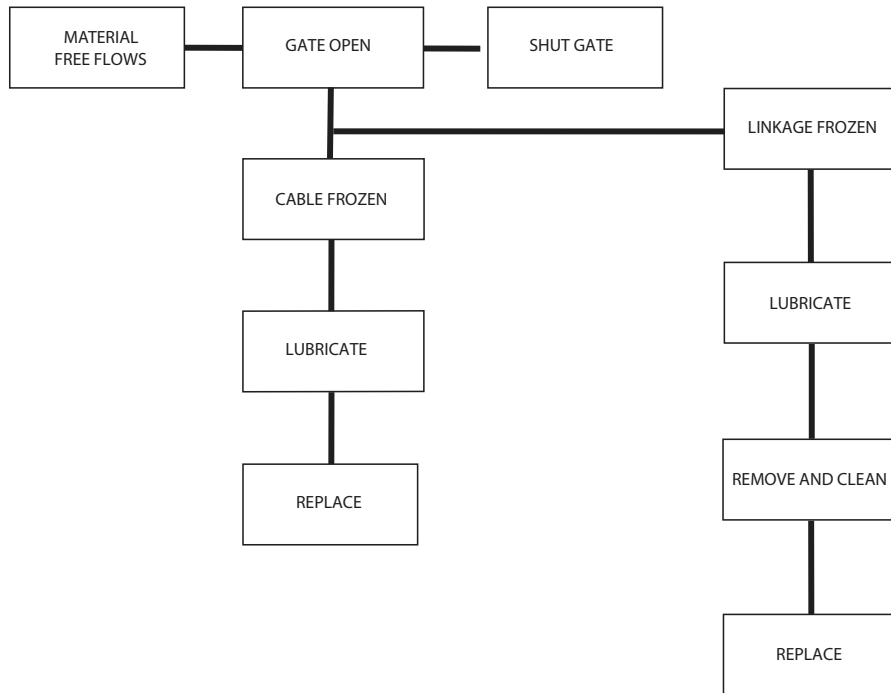

THIS PAGE INTENTIONALLY LEFT BLANK



Limited Warranty

One year warranty on Turfex brand products against defects in material or workmanship under normal use and service, subject to limitations detailed below. Warranty period of year of one year begins on the date of purchase by the original retail user.

The WARRANTY REGISTRATION CARD must be returned to the manufacturer for this warranty to become effective. This warranty applies to the original retail purchaser only. This warranty does not cover damages caused by improper installation, misuse, lack of proper maintenance, alterations or repairs made by anyone other than authorized Trynex dealers or Trynex personnel. Due to the corrosive properties of the materials dispensed by spreaders, Trynex does not warrant against damage caused by corrosion. Warranty claims by the user must be made to the dealer from where the product was purchased, unless otherwise authorized by Trynex. Trynex reserves the right to determine if any part is defective and to repair or replace such parts as it elects. This warranty does not cover shipping costs of defective parts to or from the dealer.

LIMITATION OF LIABILITY

Neither Trynex, nor any company affiliated with it, makes any warranties, representations for promise as to the performance or quality other than what is herein contained. The liability of Trynex to the purchaser for damages arising out of the manufacture, sale, delivery, use or resale of this spreader shall be limited to and shall not exceed the costs of repair or replacement of defective parts. Trynex shall not be liable for loss of use, inconvenience or any other incidental, indirect or consequential damages, so the above limitations on incidental or consequential damages may not apply to you.

NO DEALER HAS AUTHORITY TO MAKE ANY REPRESENTATION OR PROMISE ON BEHALF OF TRYNEX INTERNATIONAL, OR TO ALTER OR MODIFY THE TERMS OR LIMITATIONS OF THIS WARRANTY IN ANY WAY.

Warranty Registration and Customer Survey



To initiate the warranty on your new TurfexEx product and assure prompt warranty service, please complete the following warranty registration and customer survey, sign and mail it back to the factory within 30 days of purchase.

1) Date of Purchase: _____

2) Name: _____

Address: _____

Phone: _____

3) Turfex Model Purchased: _____ Serial Number: _____

4) Is this your first Trynex Product? Yes No

5) What type of vehicle are you using with your Spreader?

Make _____ Model _____ Year _____

6) What type of material are you using in your spreader? _____

7) SnowEx Dealer Name: _____

SnowEx Dealer Address: _____

SnowEx Dealer Phone: _____

8) Does your Trynex Dealer stock Trynex replacement Parts? Yes No I don't know

9) Do you feel your Trynex Dealer sold you the correct product for your needs/application? Yes No

10) How would you rate your overall satisfaction with your Turfex Dealer?-

<input type="checkbox"/>	<input type="checkbox"/>	<input type="checkbox"/>	<input type="checkbox"/>	<input type="checkbox"/>	<input type="checkbox"/>	<input type="checkbox"/>
Very Satisfied	Satisfied	Somewhat Satisfied	Somewhat Dissatisfied	Dissatisfied		Very Dissatisfied

11) How would you rate your overall satisfaction with your Turfex Product?

<input type="checkbox"/>	<input type="checkbox"/>	<input type="checkbox"/>	<input type="checkbox"/>	<input type="checkbox"/>	<input type="checkbox"/>	<input type="checkbox"/>
Very Satisfied	Satisfied	Somewhat Satisfied	Somewhat Dissatisfied	Dissatisfied		Very Dissatisfied

12) Would you purchase another Trynex Product? Yes No

13) If you would like to receive E-Mail ALERTS for new products, bulletins or special promotions please supply address: _____

14) Please use the space below to convey your comments and/or suggestions.

NOTE: I have read the owner's manual and all safety precautions and I understand that this equipment could be dangerous if not operated with care and under the proper conditions.

15) Owner's signature: X _____

PLEASE FOLD AND SEAL WITH TRANSPARENT TAPE BEFORE MAILING.

Simply Fill Out Your Warranty Registration and Return It to the Factory!

From:



Postage
Required
Post Office will
not deliver
without proper
postage.



23455 REGENCY PARK DR.
WARREN MI 48089-2667

